

	Philmont Scout Ranch RED ROOF INN		Title: RED ROOF INN	
			Tolerances: N/A	
Drawn by: Ronald La Curan		N/A	Index:	
Date: 23-Mar-09	Scale: N/A	Version: 1	Page 1 of 24	

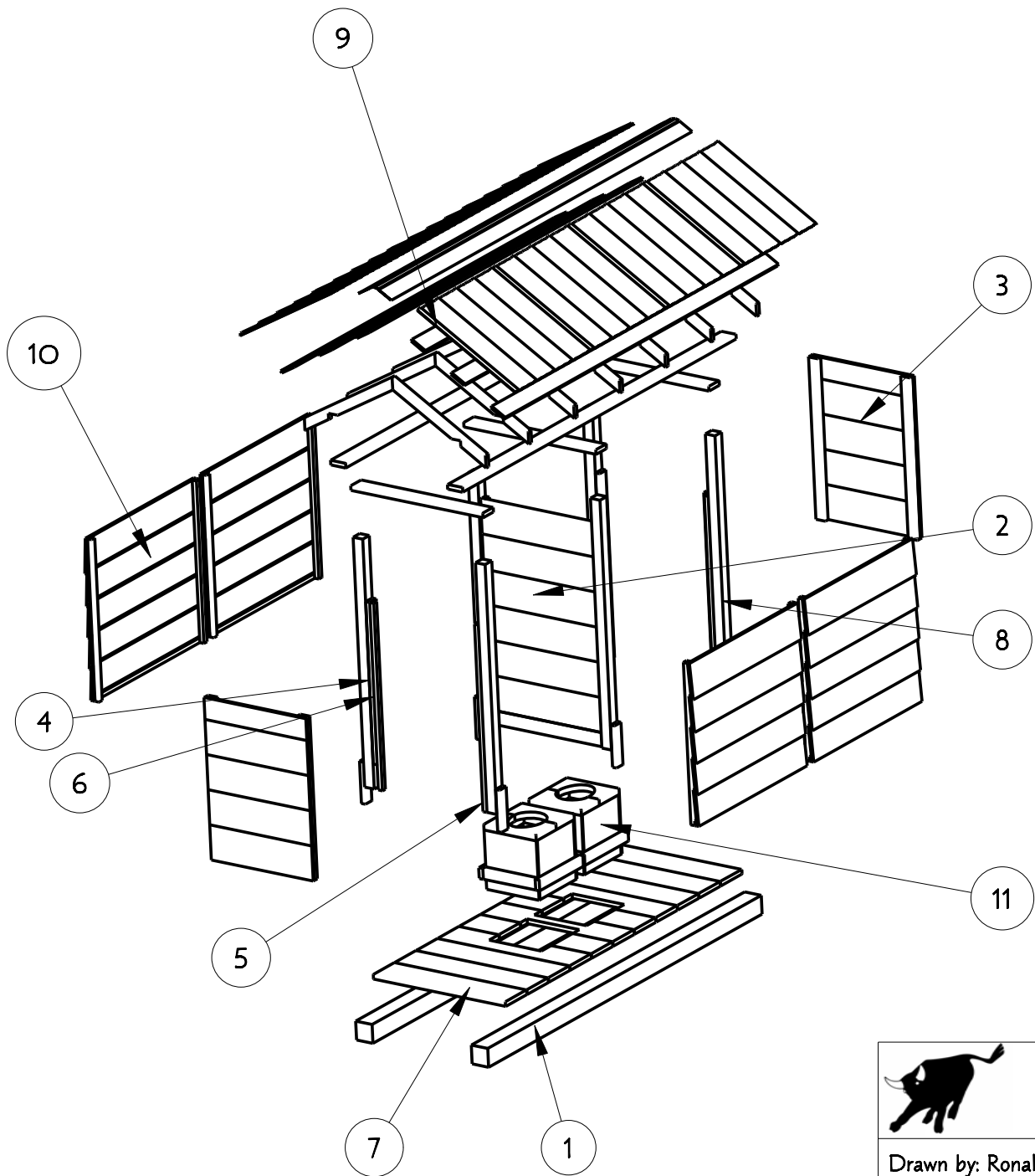

Index	Part Name	Qty.
1	BASE	2
2	CENTER_WALL	1
3	DOOR	2
4	DOOR_STOP_1	2
5	DOOR_STOP_2	2
6	DOOR_STOP_3	2
7	FLOOR	11
8	POSTS	6
9	ROOF_ASM	1
10	SIDE_WALL	4
11	TOILET_SEAT	2

	Philmont Scout Ranch RED ROOF INN		Title: RED ROOF INN	
			Tolerances: N/A	
Drawn by: Ronald La Curan		N/A	Index:	
Date: 23-Mar-09	Scale: N/A	Version: 1	Page 2 of 24	

Index	Part Name	Description	Qty
1	FLOOR	2x12 Planed 48" Long	11
2	BASE	6x6 Rough Cut 144" Long	2

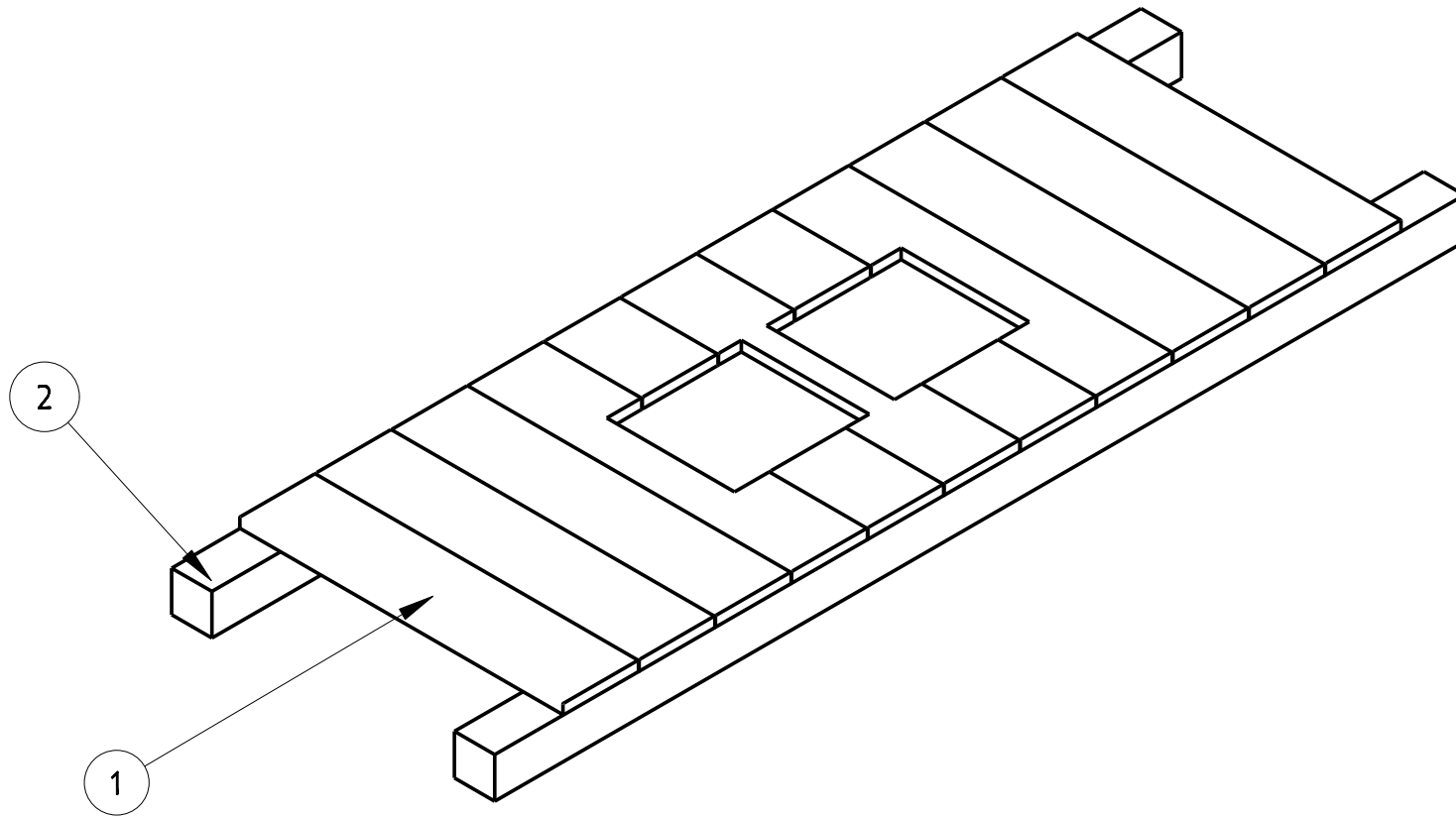

	Philmont Scout Ranch RED ROOF INN		Title: BASE ASSEMBLY	
			Tolerances: N/A	
Drawn by: Ronald La Curan		N/A	Index: 1 & 7	
Date: 23-Mar-09	Scale: N/A	Version: 1	Page 3 of 24	

Index	Part Name	Description	Qty
1	CEN_WALL_PANEL	1x12 Planed 41" Long	6
2	CEN_WALL_PANEL_SM	1x2 Planed 41" Long	1
3	CEN_WALL_FRAME	2x4 Planed 72" long	2

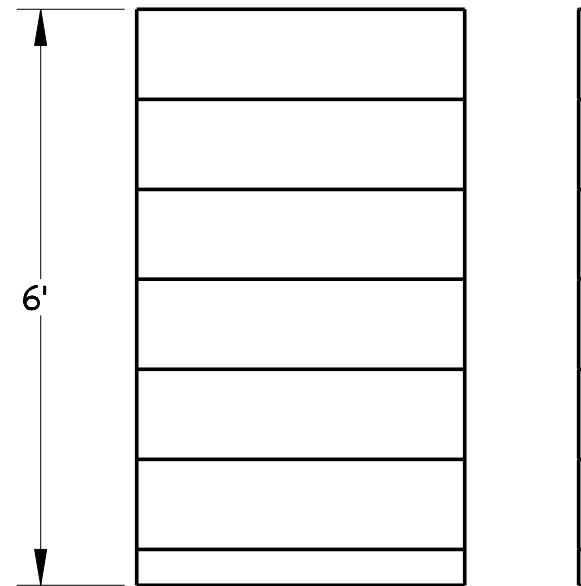
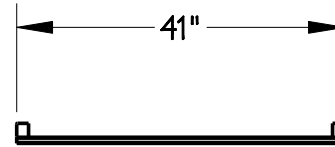
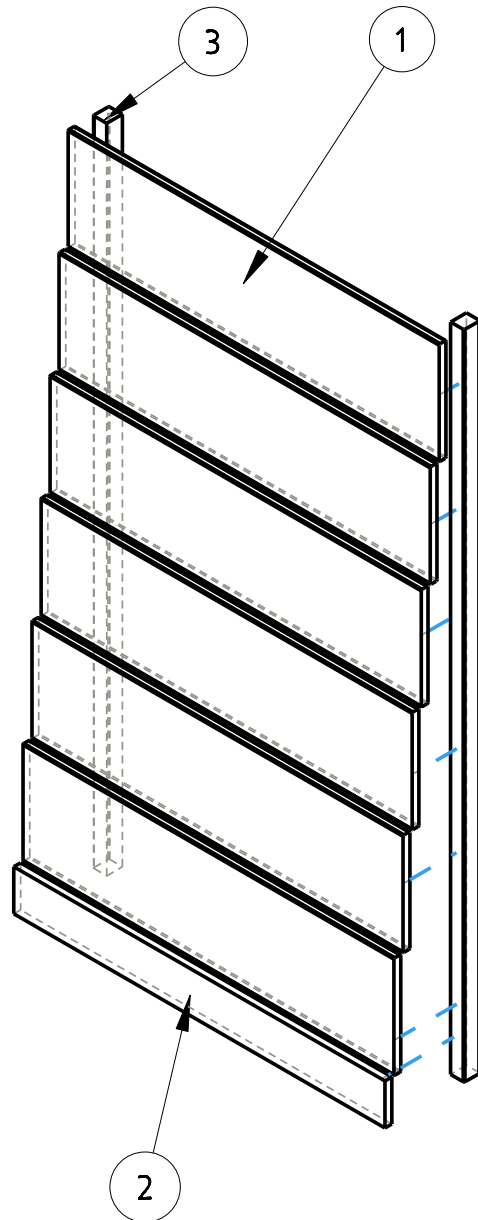

	Philmont Scout Ranch RED ROOF INN		Title: CENTER WALL ASSEMBLY	
			Tolerances: N/A	
Drawn by: Ronald La Curan		N/A	Index: 2	
Date: 23-Mar-09	Scale: N/A	Version: 1	Page 4 of 24	

Index	Part Name	Description	Qty
1	DOOR_PANEL	1x12 Planed 37" Long	4
2	DOOR_FRAME	2x4 Planed 52" Long	2
3	DOOR_PANEL_SM	Cut to fit.	1

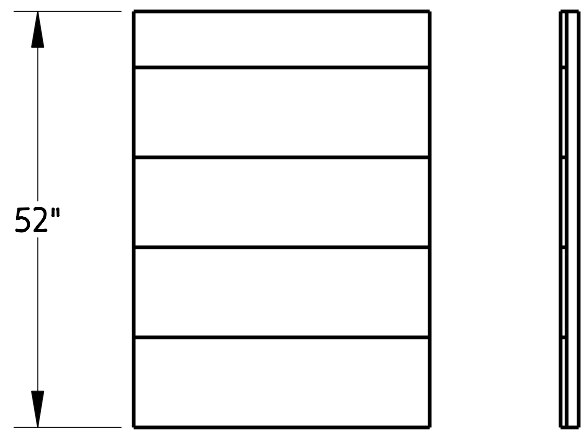
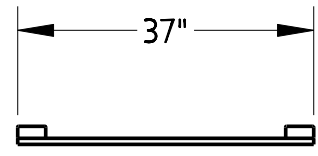
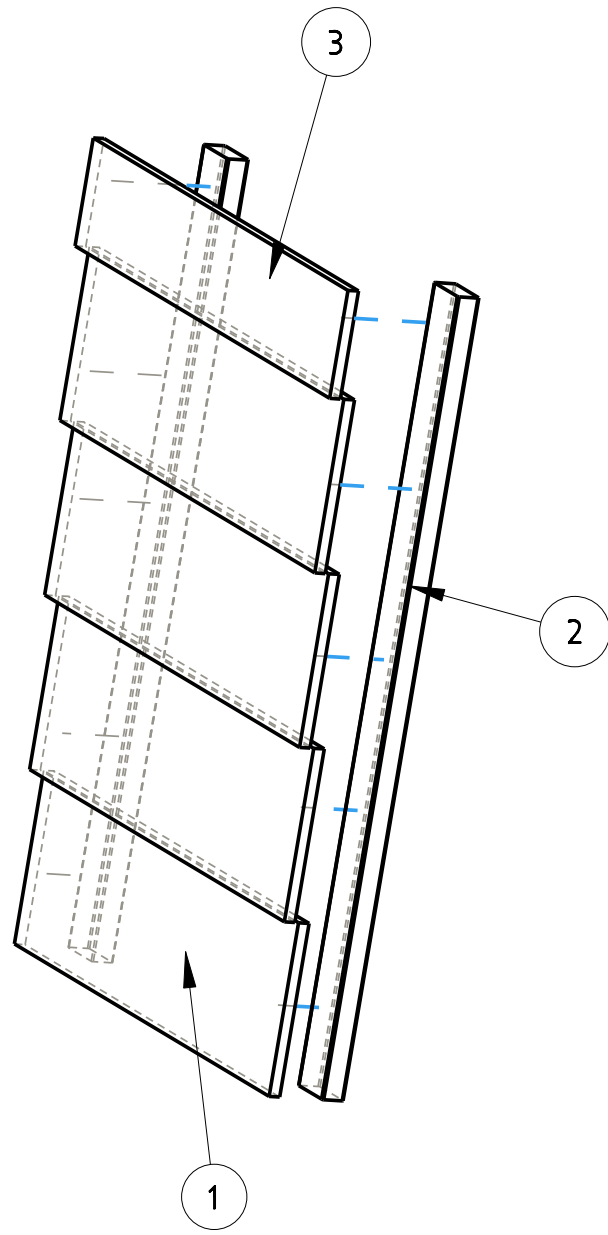



4	DOOR_STOP_1	2x4 Planed 52" Long	1
5	DOOR_STOP_2	2x4 Planed 60" Long	1
6	DOOR_STOP_3	2x2 Planed 60" Long	1

* Parts 4,5 & 6 are not pictured.

	Philmont Scout Ranch RED ROOF INN		Title: DOOR ASSEMBLY	
			Tolerances: N/A	
Drawn by: Ronald La Curan		N/A	Index: 3-6	
Date: 23-Mar-09	Scale: N/A	Version: 1	Page 5 of 24	

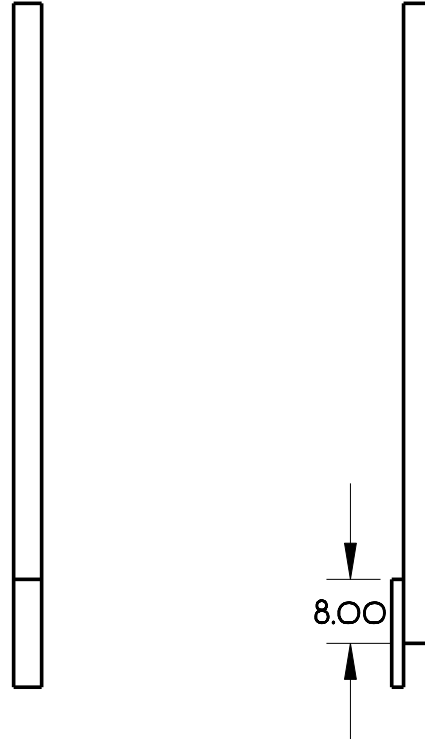
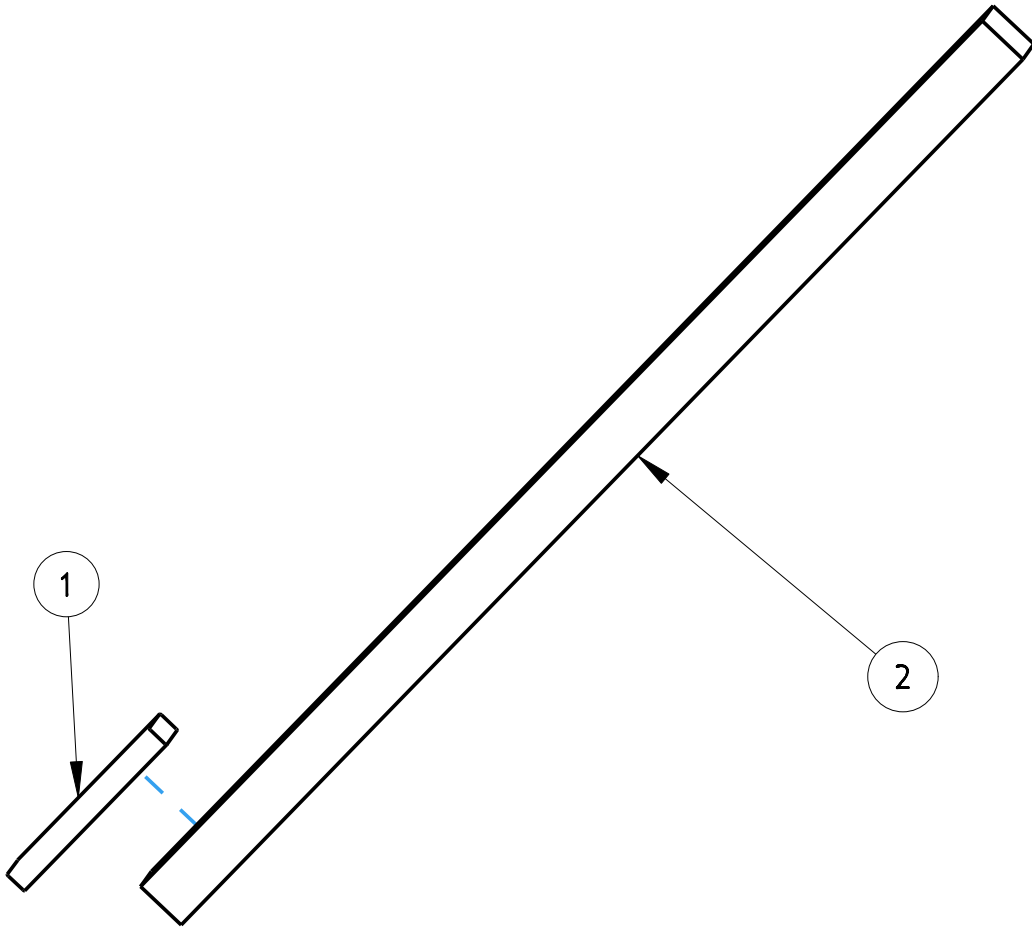
Index	Part Name	Description	Qty
1	POST_SUPPORTS	2x4 Planed 13.5" Long	1
2	POST	4x4 Planed 80" Long	1



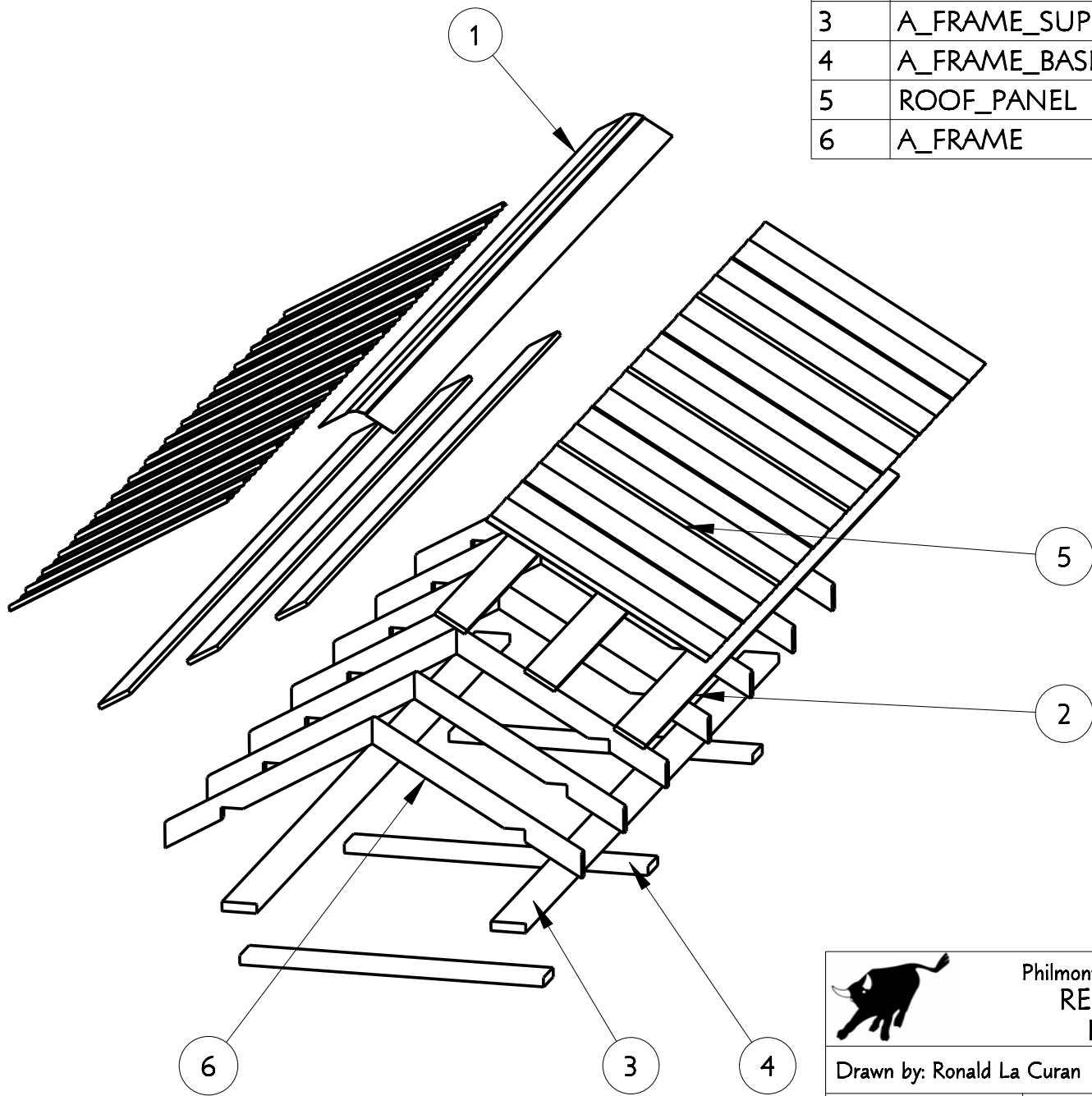

	Philmont Scout Ranch RED ROOF INN		Title: POST ASSEMBLY
			Tolerances: N/A
Drawn by: Ronald La Curan		N/A	Index: 8
Date: 23-Mar-09	Scale: N/A	Version: 1	Page 6 of 24

Index	Part Name	Description	Qty.
1	ROOF_PEAK	158-1/2" Pro-Panel Peak	1
2	ROOF_SLATS	1x6 Planed 144" Long	6
3	A_FRAME_SUPPORT	2x6 Planed 144" Long	2
4	A_FRAME_BASE	2x6 Planed 48" Long	3
5	ROOF_PANEL	3ft Pro-Panel Sections	8
6	A_FRAME	See Next Page	7



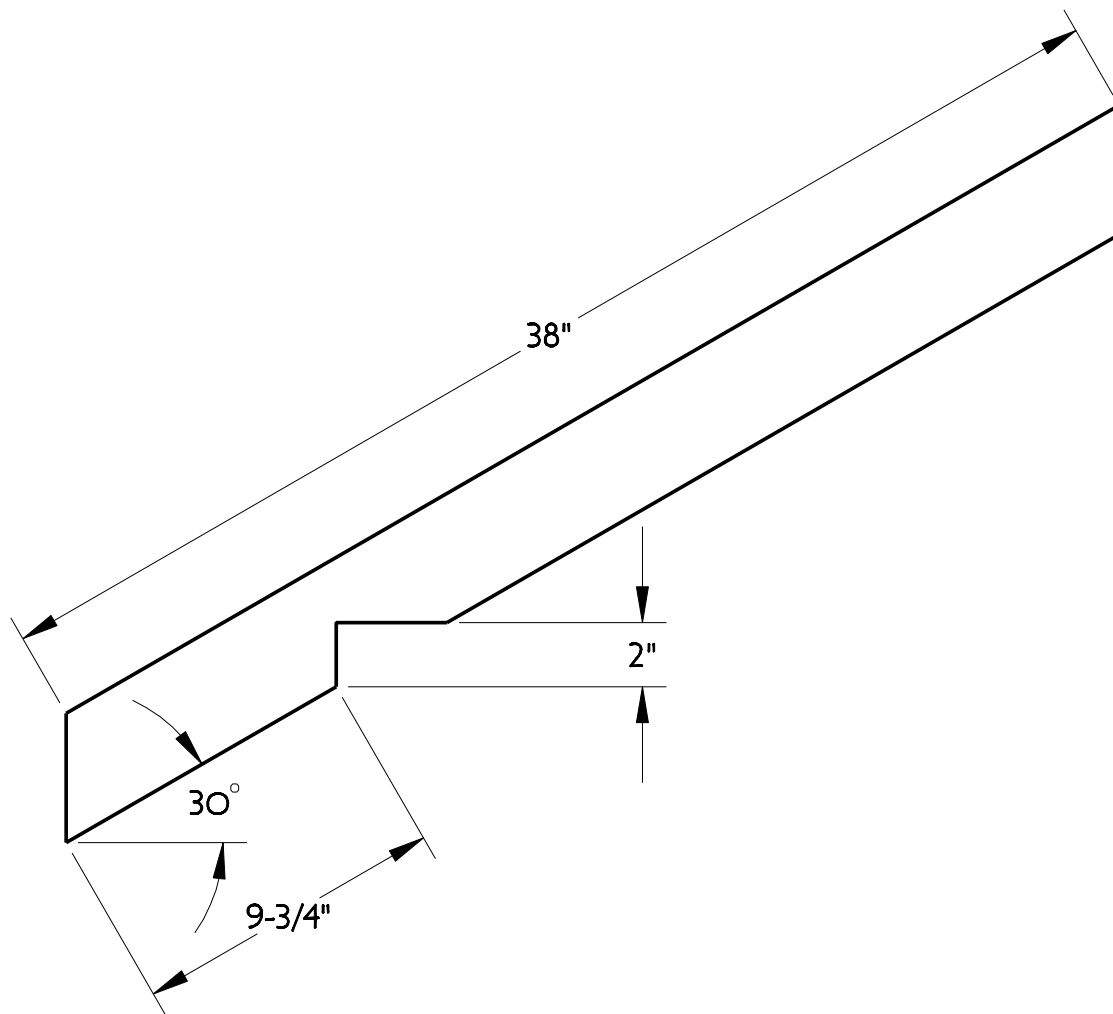

	Philmont Scout Ranch RED ROOF INN		Title: ROOF ASSEMBLY	
			Tolerances: N/A	
Drawn by: Ronald La Curan		N/A	Index: 9	
Date: 23-Mar-09	Scale: N/A	Version: 1	Page 7 of 24	



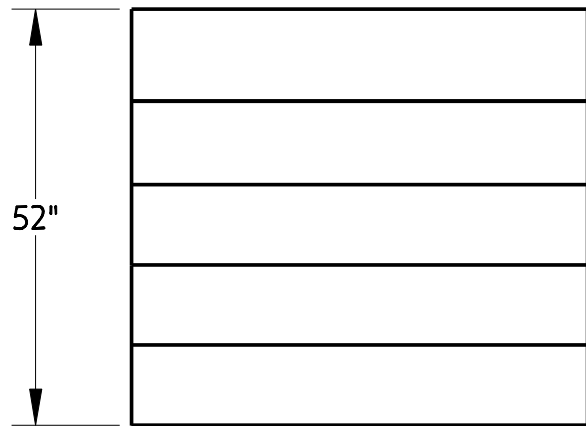
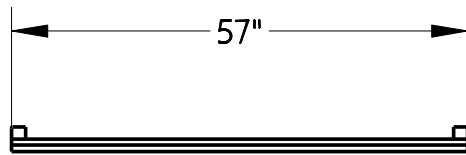
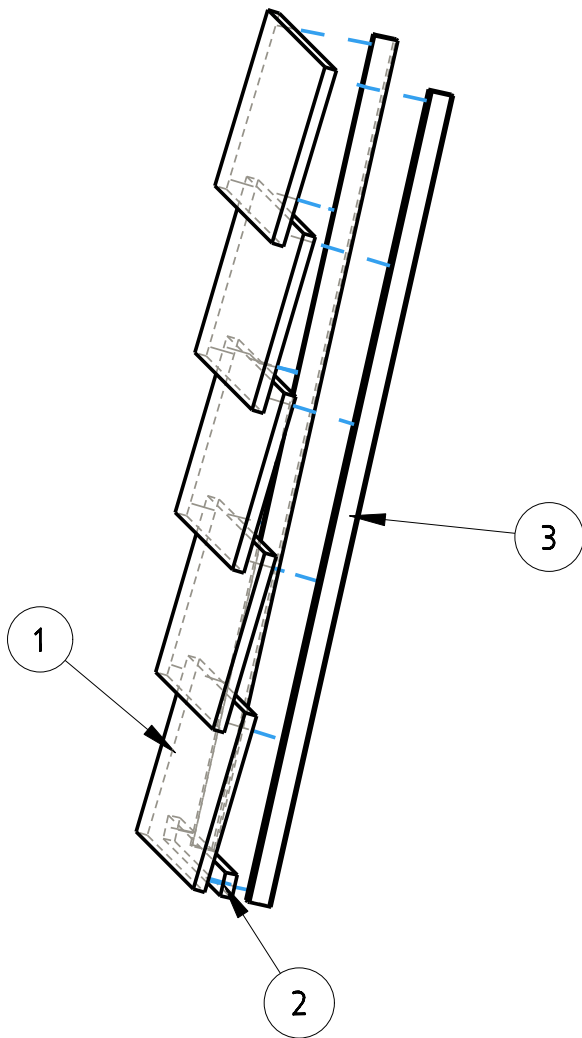

	Philmont Scout Ranch RED ROOF INN		Title: A FRAME DIMENSIONS	
			Tolerances: N/A	
Drawn by: Ronald La Curan		N/A	Index: N/A	
Date: 23-Mar-09	Scale: 1:6	Version: 1	Page 8 of 24	

Index	Part Name	Description	Qty
1	SIDE_WALL_PLANK	1x10 Planed 57" Long	5
2	SIDE_WALL_FRAME_2	1x4 Planed 57" Long	1
3	SIDE_WALL_FRAME_1	2x2 Planed 52" Long	2

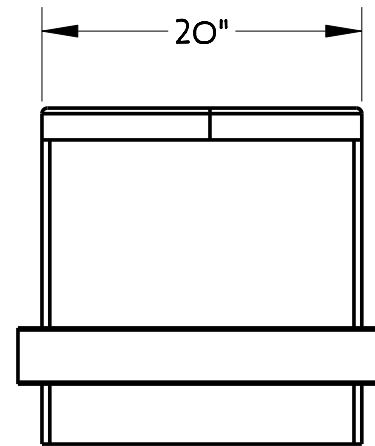
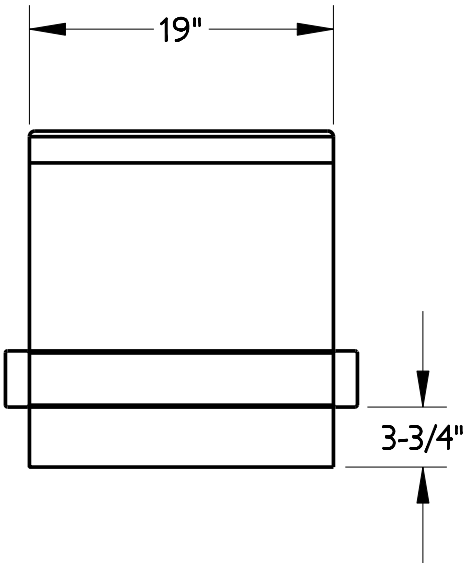
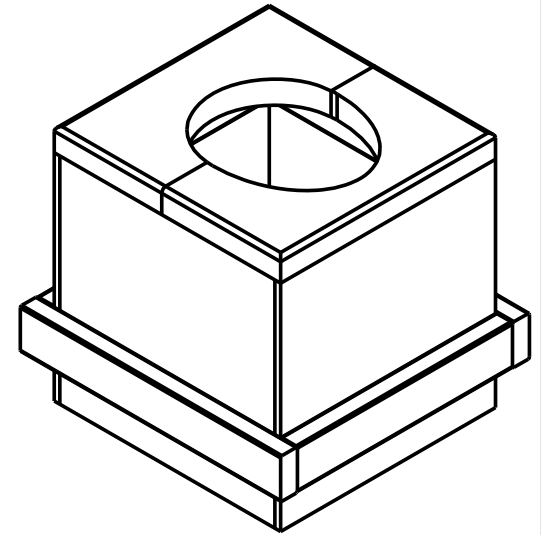
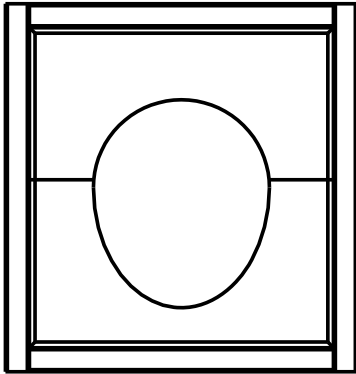

	Philmont Scout Ranch RED ROOF INN		Title: SIDE WALL	
			Tolerances: N/A	
Drawn by: Ronald La Curan		N/A		Index: 10
Date: 23-Mar-09	Scale: N/A	Version: 1	Page 9 of 24	



	Philmont Scout Ranch RED ROOF INN		Title: TOILET SEAT	
			Tolerances: N/A	
Drawn by: Ronald La Curan		N/A	Index: 11	
Date: 23-Mar-09	Scale: N/A	Version: 1	Page 10 of 24	

Index	Part Name	Description	Qty
1	SEAT_TOP_LG	2x10.5x19 Planed	1
2	SEAT_FRAME_3	2x4 Planed 15" Long	2
3	SEAT_FRAME_1	2x4 Planed 19" Long	2
4	SEAT_FRAME_4	2x4 Planed 19" Long	2
5	SEAT_FRAME_2	2x4 Planed 23" Long	2
6	SEAT_TOP_SM	2x9.5x19 Planed	1
7	SEAT_WALL	3/4" Plywood 19x19	4

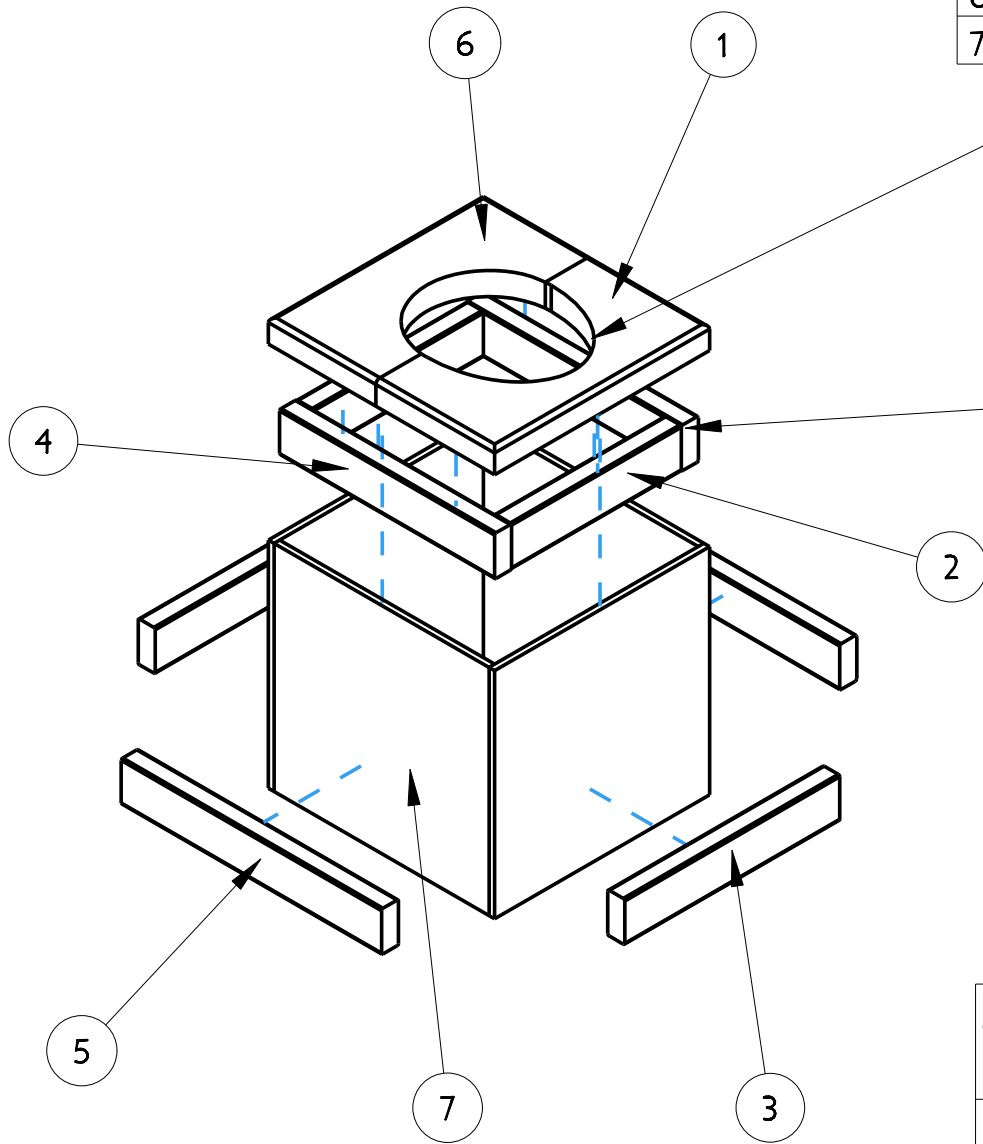

Center your toilet seat w/lid on the top of the structure and trace the inside of the ring with a marker. Using a chainsaw or other suitable cutting device, cut out the traced shape of the hole and then attach the plastic toilet seat and lid.

The framing composed of parts 2 and 4 sit flush with the top of the box composed of part 7.

	Philmont Scout Ranch RED ROOF INN		Title: TOILET SEAT	
			Tolerances: N/A	
Drawn by: Ronald La Curan		N/A	Index: 11	
Date: 23-Mar-09	Scale: N/A	Version: 1	Page 11 of 24	

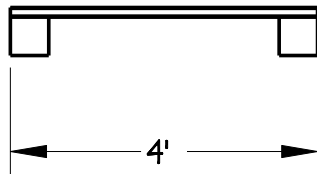
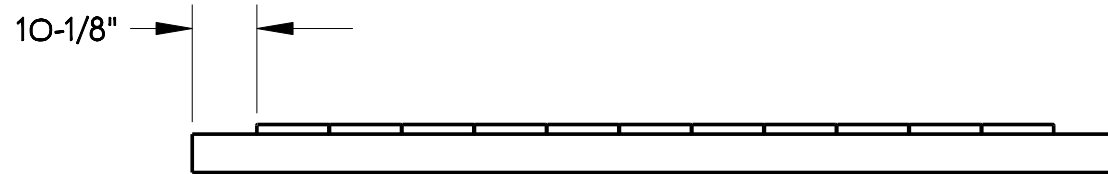
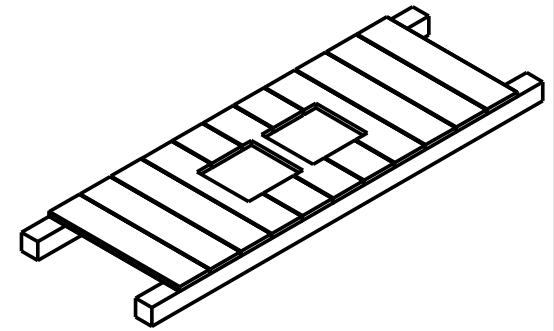

	Philmont Scout Ranch RED ROOF INN		Title: ASSEMBLY 1	
			Tolerances: N/A	
Drawn by: Ronald La Curan		N/A	Index:	
Date: 23-Mar-09	Scale: N/A	Version: 1	Page 12 of 24	

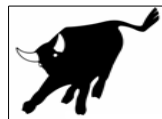
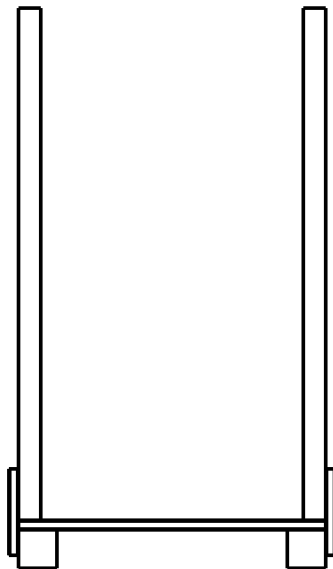
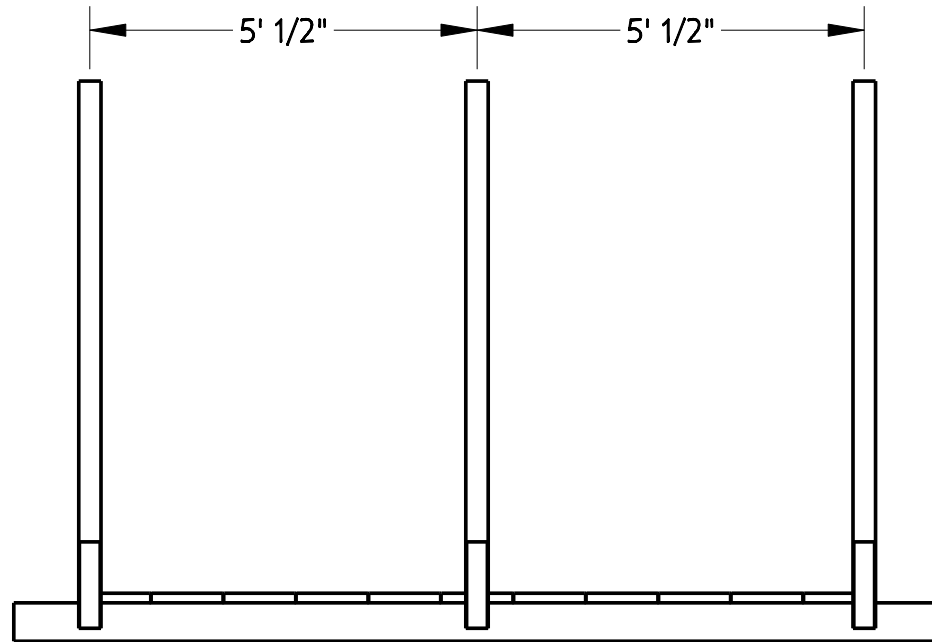
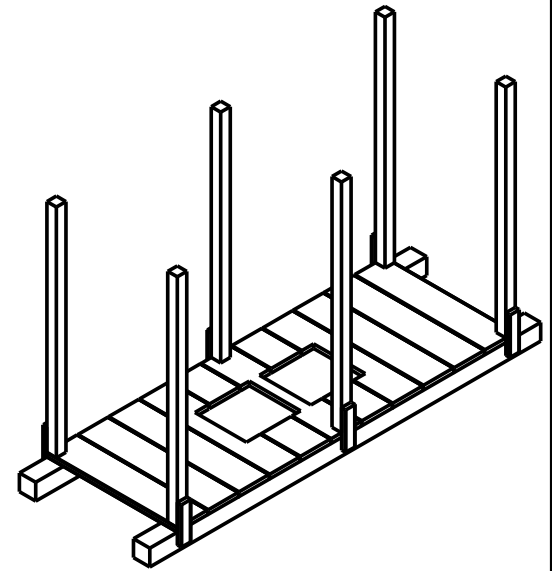

Philmont Scout Ranch
 RED ROOF
 INN

Title: ASSEMBLY 2

Tolerances: N/A

Drawn by: Ronald La Curan

N/A

Index:

Date: 23-Mar-09

Scale: N/A

Version: 1

Page 13 of 24

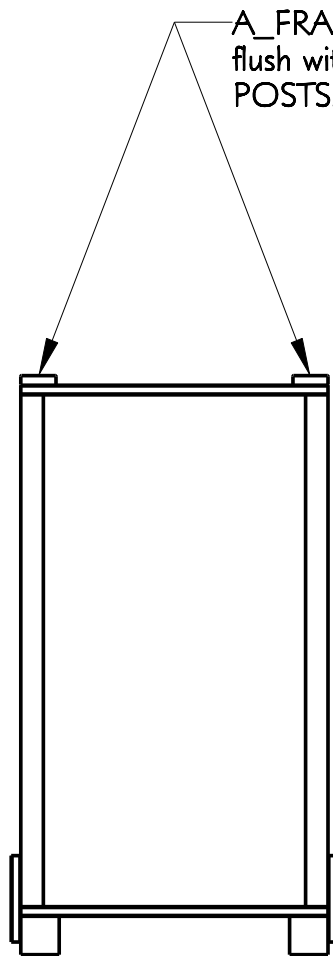

A_FRAME_SUPPORTS will be flush with the outer edges of the POSTS.

Outer edges of the left and right A_FRAME_BASES will be flush with the outer edges of the POSTS. The middle A_FRAME_BASE will be centered over the middle POST.

9-3/4"

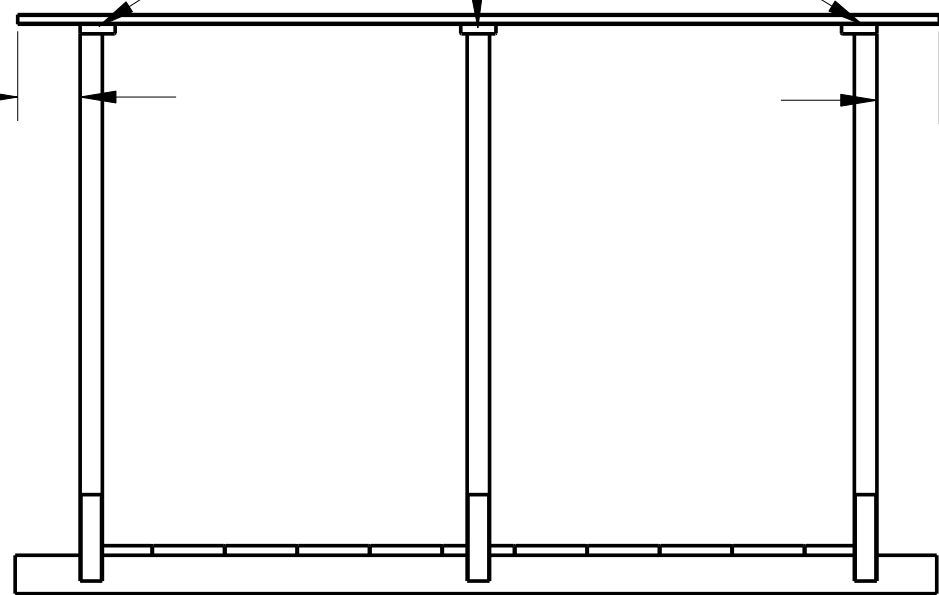

9-3/4"

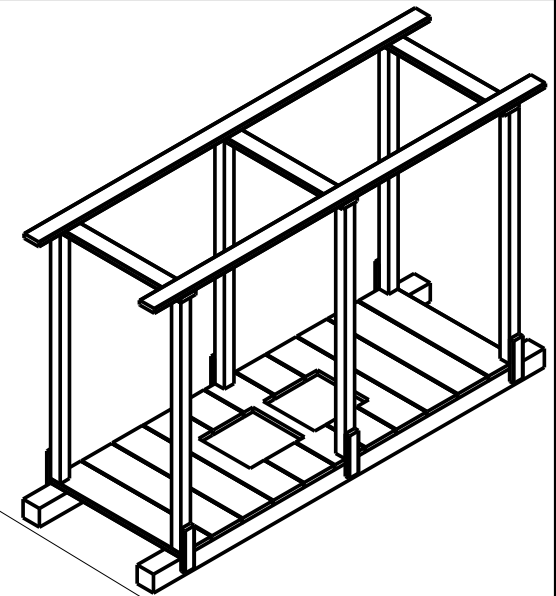

Philmont Scout Ranch
RED ROOF
INN

Title: ASSEMBLY 3

Tolerances: N/A

Drawn by: Ronald La Curan

N/A

Index:

Date: 23-Mar-09

Scale: N/A

Version: 1

Page 14 of 24

A_FRAME assemblies are to be spaced in 2ft intervals from the center to center with the two A_FRAME assemblies on either side of the Red Roof Inn being flush with the ends of the A_FRAME_SUPPORTs they are resting on. This will result in there only being a spacing of 22-1/2" between the final two A_FRAME assemblies on one side.

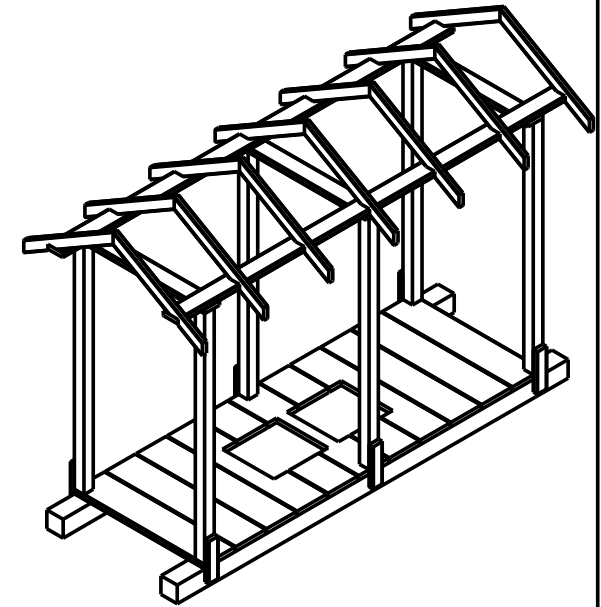
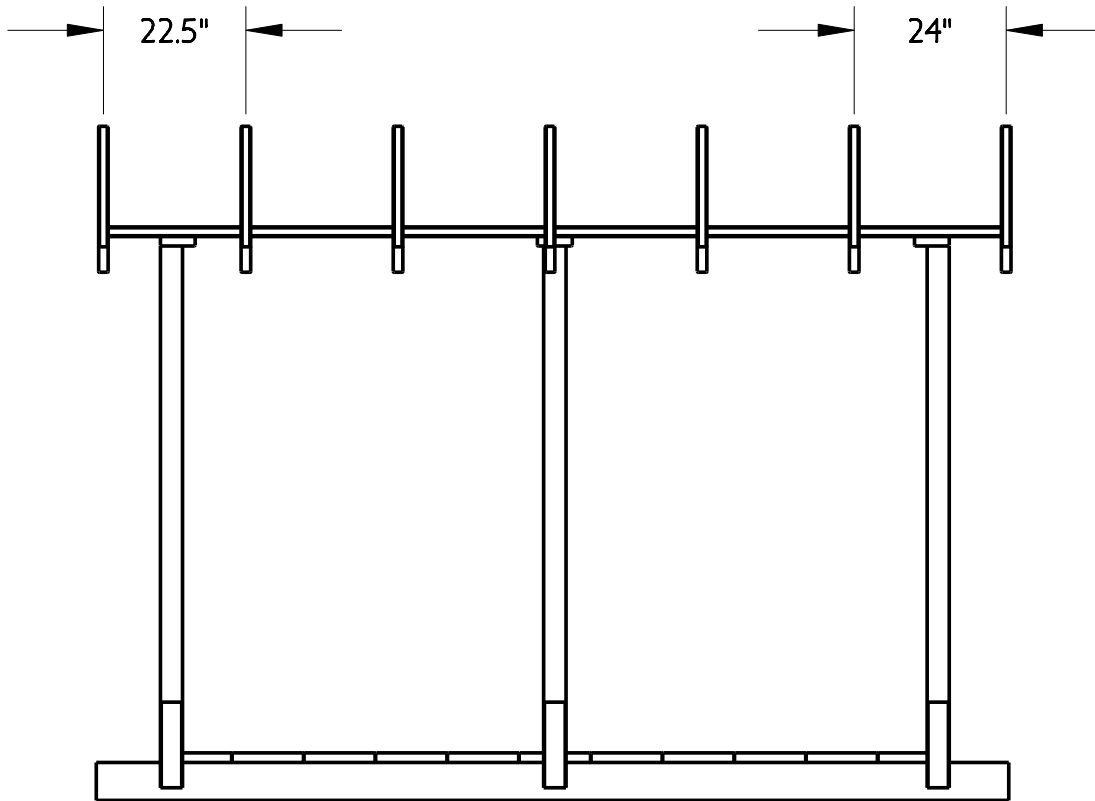

	Philmont Scout Ranch RED ROOF INN		Title: ASSEMBLY 4	
			Tolerances: N/A	
Drawn by: Ronald La Curan		N/A	Index:	
Date: 23-Mar-09	Scale: N/A	Version: 1	Page 15 of 24	

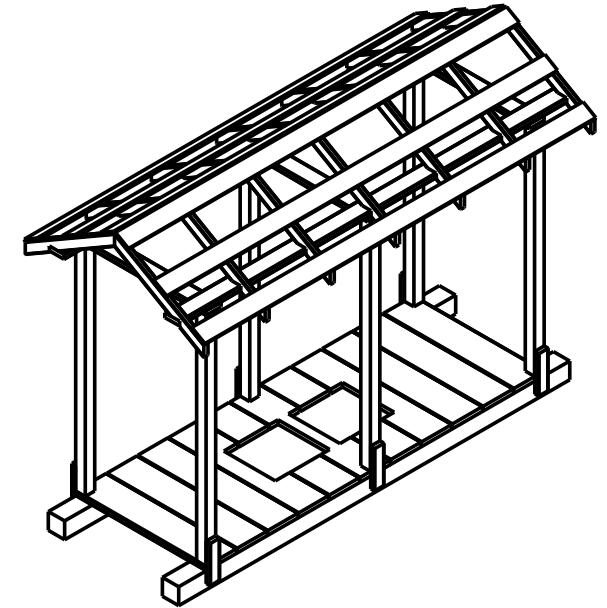
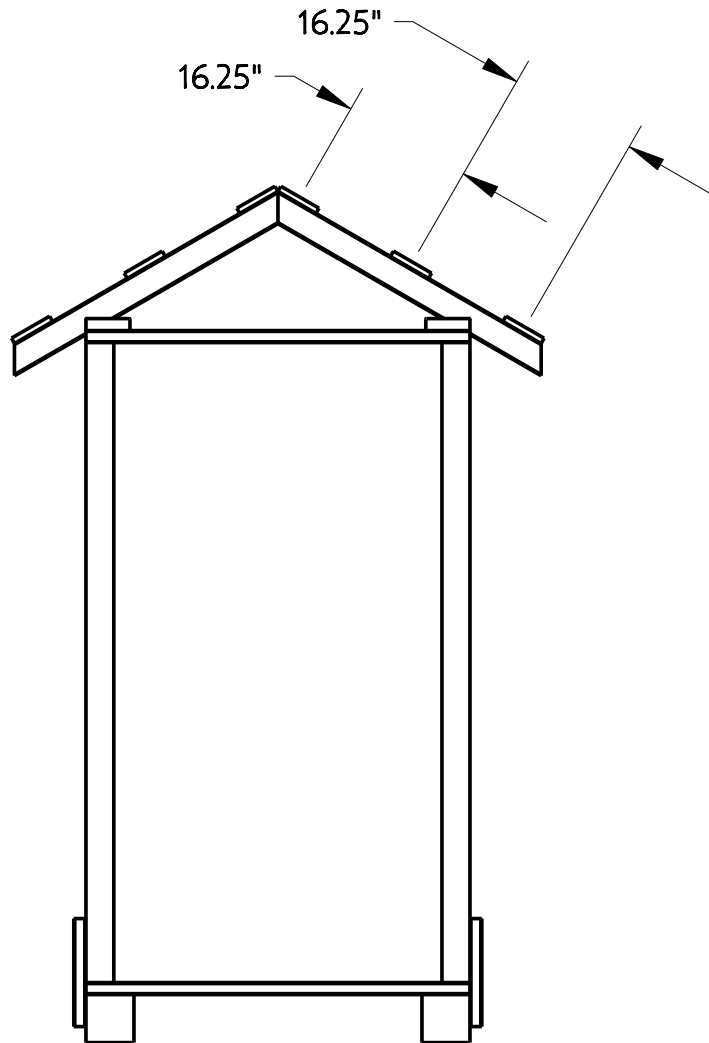

The sides of the two outer ROOF_SLATS should be flush with the edge and the peak of the A_FRAME assemblies. The third should be located in between them, roughly 16-1/4" from centerline to centerline of either of the outer ROOF_SLATS.



Philmont Scout Ranch
RED ROOF
INN

Title: ASSEMBLY 5

Tolerances: N/A

Drawn by: Ronald La Curan

N/A

Index:

Date: 23-Mar-09

Scale: N/A

Version: 1

Page 16 of 24

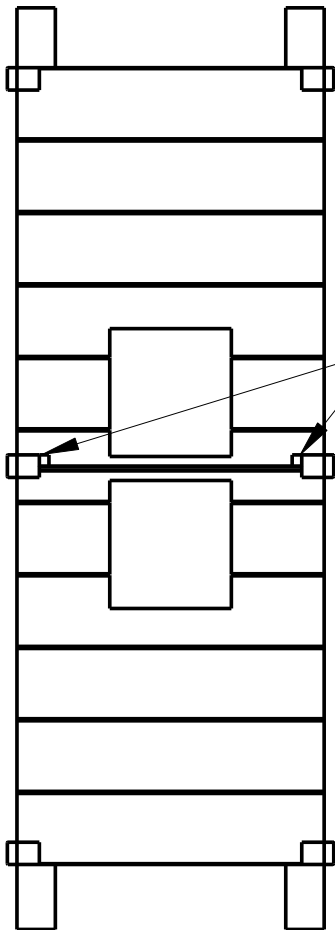

The CENTER_WALL assembly will fit exactly between the two center POSTs. It should be placed flush on the floor boards and arrange the wall such that the back sides of the framing on the CENTER_WALL are flush with one side of the two center POSTS. This will center the CENTER_WALL adequately.

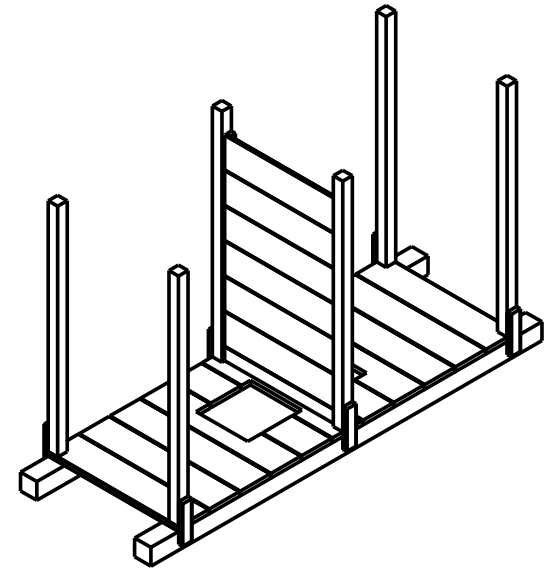

	Philmont Scout Ranch RED ROOF INN		Title: ASSEMBLY 6	
			Tolerances: N/A	
Drawn by: Ronald La Curan		N/A	Index:	
Date: 24-Mar-09	Scale: N/A	Version: 1	Page 17 of 24	

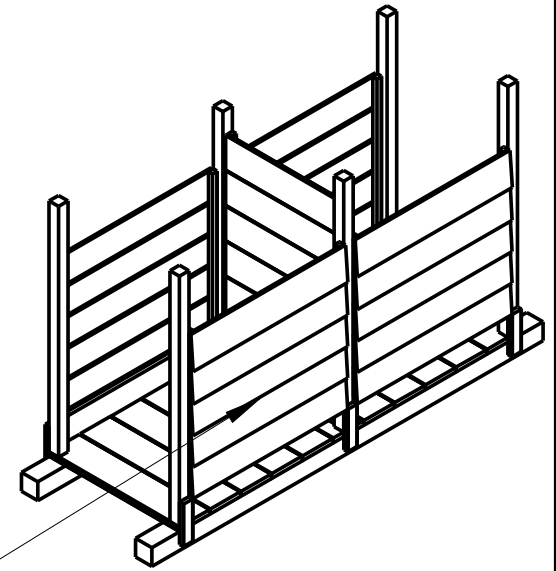
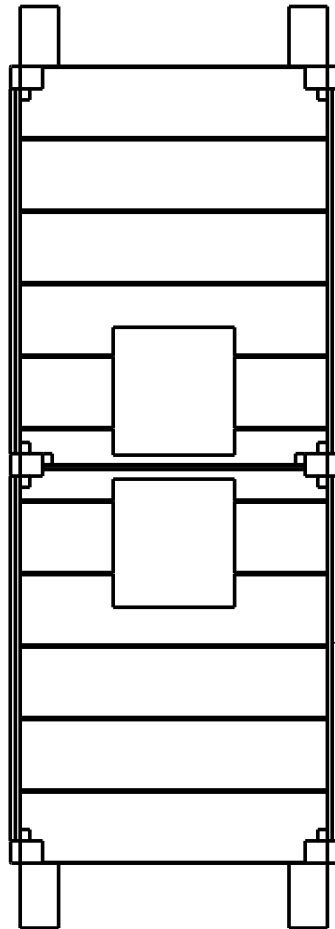

Each SIDE_WALL assembly should fit exactly between the POSTs already in place. They should be aligned such that the front side of the vertical framing on them (the side that the planking attaches to) is flush with the outer side of the POSTs.

	Philmont Scout Ranch RED ROOF INN		Title: ASSEMBLY 7A	
			Tolerances: N/A	
Drawn by: Ronald La Curan		N/A		Index:
Date: 24-Mar-09	Scale: N/A	Version: 1	Page 18 of 24	

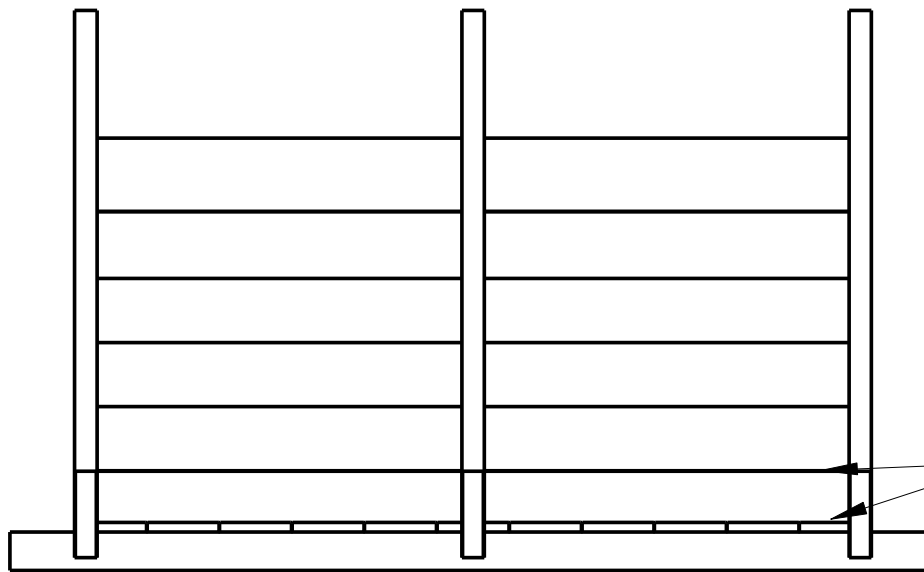

The proper gap here can be achieved by using two 2x4x8" blocks lightly nailed into the bordering POSTs. After being nailed in place, set the SIDE_WALL on top of the two blocks and this will ensure the wall is attached level and provide a stable platform for the wall to sit on while being attached.



Philmont Scout Ranch
**RED ROOF
 INN**

Title: ASSEMBLY 7B

Tolerances: N/A

Drawn by: Ronald La Curan

N/A

Index:

Date: 24-Mar-09

Scale: N/A

Version: 1

Page 19 of 24

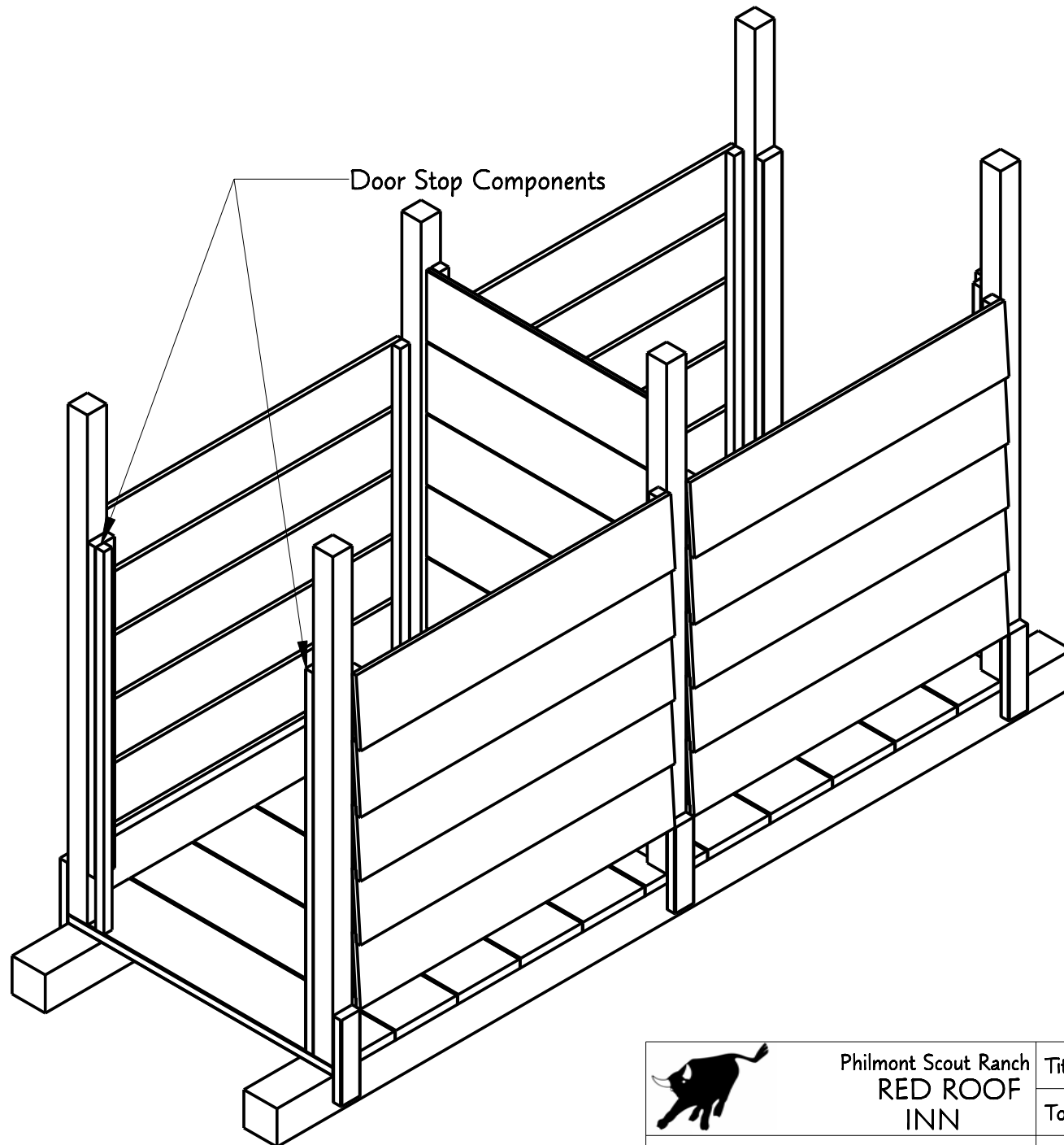

	Philmont Scout Ranch RED ROOF INN		Title: ASSEMBLY 8A	
			Tolerances: N/A	
Drawn by: Ronald La Curan		N/A	Index:	
Date: 24-Mar-09	Scale: N/A	Version: 1	Page 20 of 24	

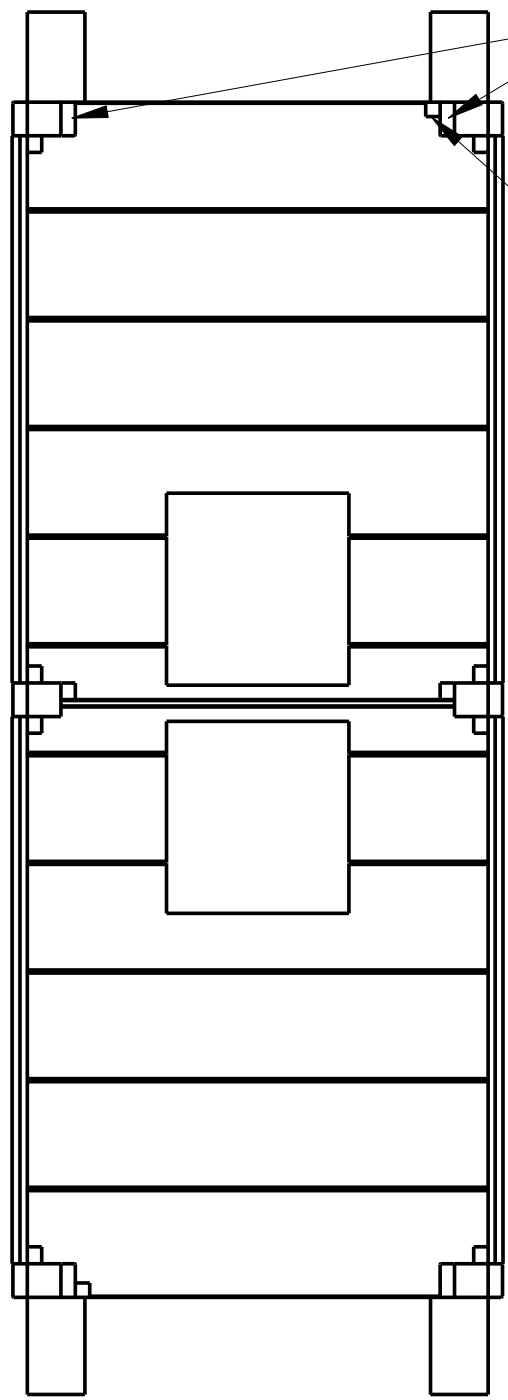

DOOR_STOP_1 and DOOR_STOP_2 are nailed into the POSTs flush against the POSTs.

DOOR_STOP_3 is a 2x2 that will be located on the left hand side POST. It should be placed flush with the side of the POST closest to you if you were looking into the structure from outside.



Philmont Scout Ranch
**RED ROOF
 INN**

Title: ASSEMBLY 8B	
Tolerances: N/A	
Drawn by: Ronald La Curan	Index:
Date: 24-Mar-09	Page 21 of 24

N/A	Version: 1
Scale: N/A	

Attach hinges here
for door assembly

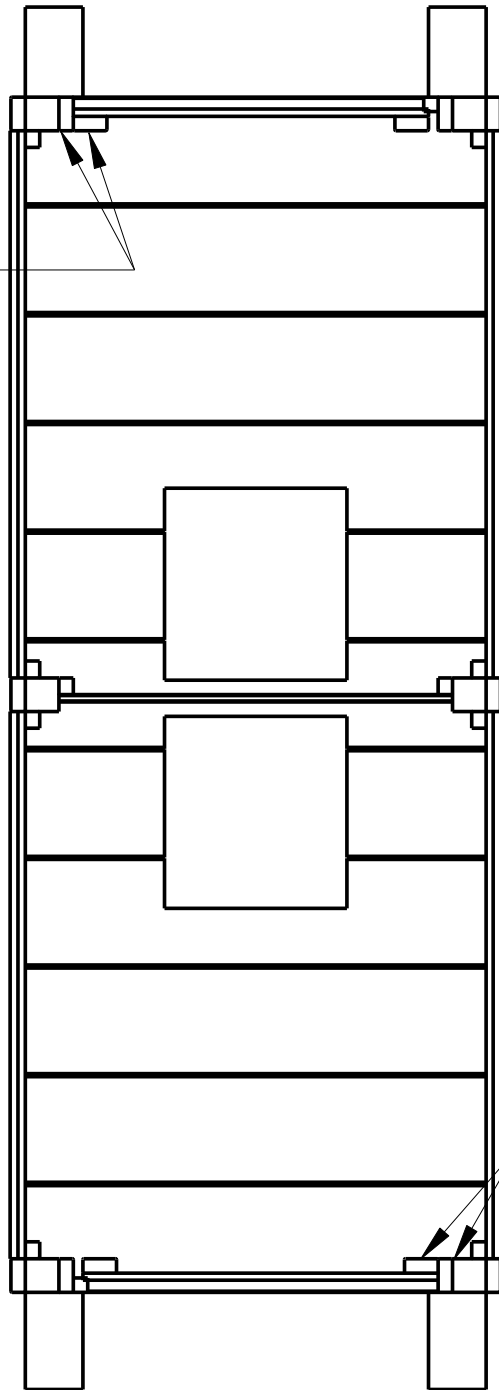

Attach hinges here for door assembly.

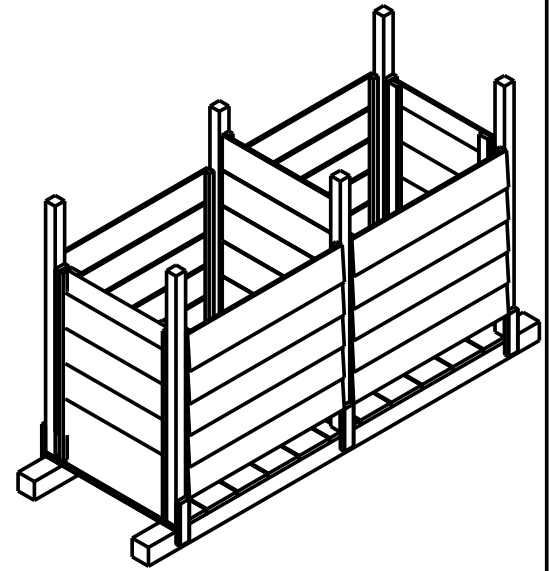

	Philmont Scout Ranch RED ROOF INN	Title: ASSEMBLY 9A	
		Tolerances: N/A	
Drawn by: Ronald La Curan		N/A	Index:
Date: 24-Mar-09	Scale: N/A	Version: 1	Page 22 of 24

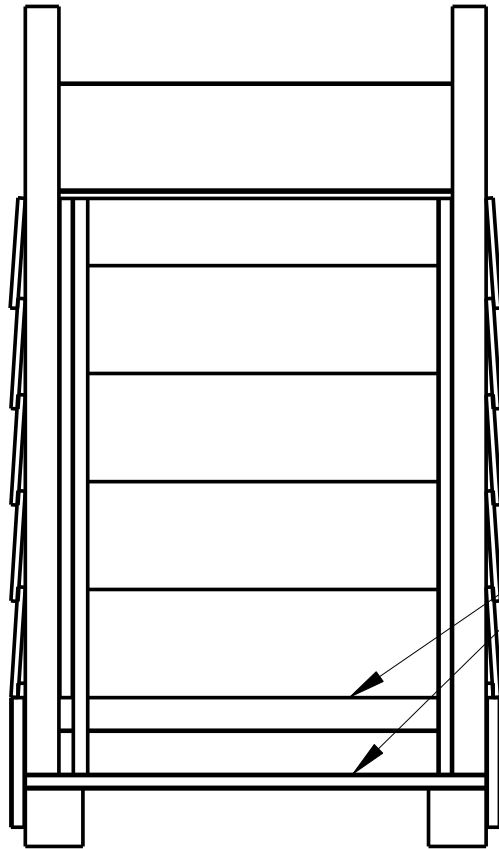

As with the SIDE_WALLS, to achieve the proper gap, use the two 2x4x8" blocks attached to the posts. Set the door on top of the blocks and attach the hinges at the locations specified. They should be at least 6" (vertically) from the top of the bottom of the door

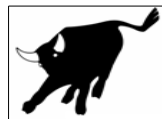

Philmont Scout Ranch
RED ROOF
INN

Title: ASSEMBLY 9B

Tolerances: N/A

Drawn by: Ronald La Curan

N/A

Index:

Date: 24-Mar-09

Scale: N/A

Version: 1

Page 23 of 24

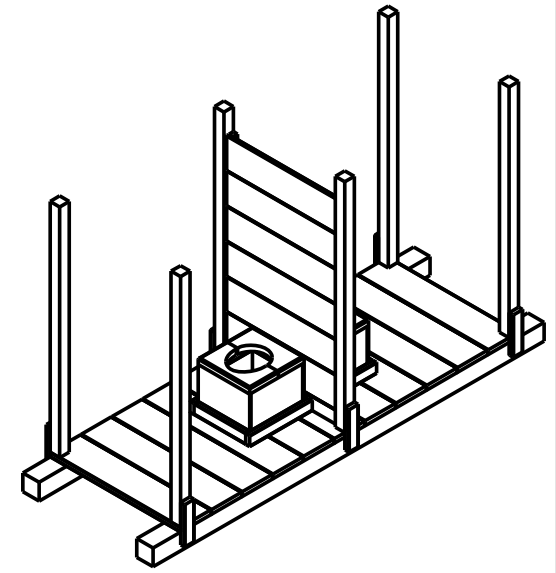
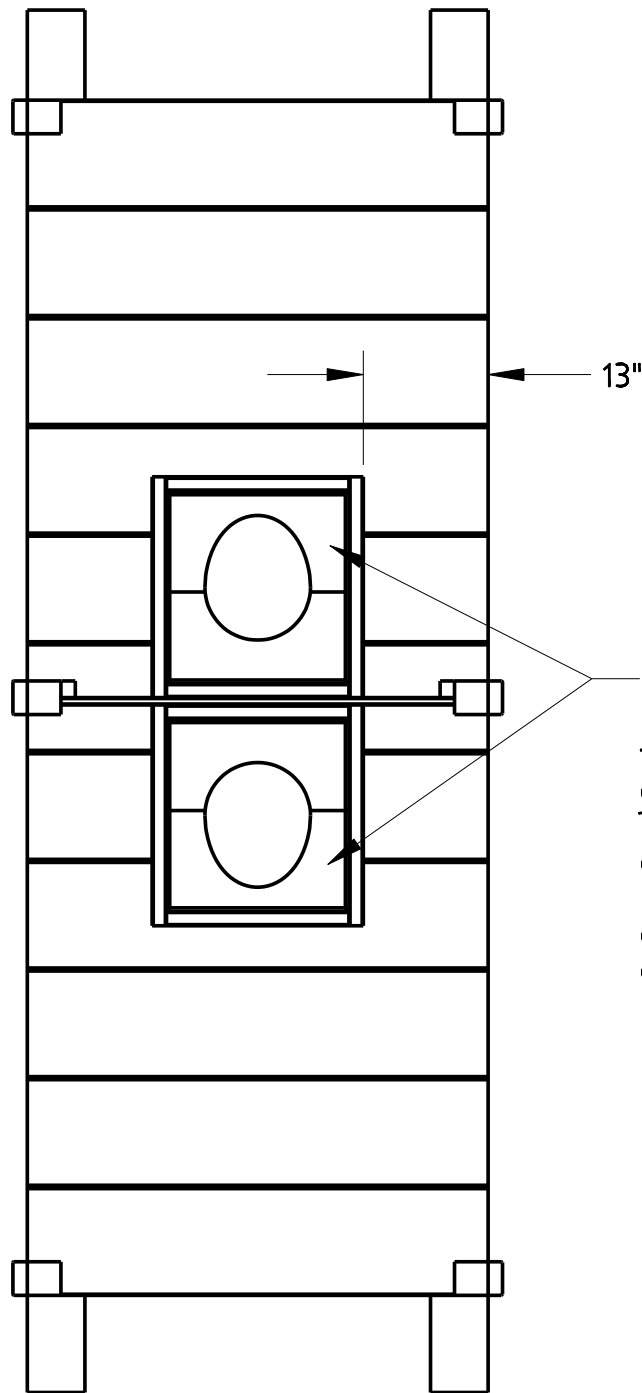

Place TOILET_SEAT so that the rear-most portion of the outer frame is up against the CENTER_WALL. Then center the TOILET_SEAT along the floor boards. A dimension has been provided for assistance. Once centered, using a marker, trace around the box base of the TOILET_SEAT, remove the TOILET_SEAT and use a chain saw to cut out the hole. The TOILET_SEAT should slide into place then. IMPORTANT: Trace only the box made up of the 3/4" plywood portion of the TOILET_SEAT, not around the 2x4 outer frame. If you use the outer frame, the TOILET_SEAT will fall right through the floor.



Philmont Scout Ranch
RED ROOF
INN

Title: ASSEMBLY 10

Tolerances: N/A

Drawn by: Ronald La Curan

N/A

Index:

Date: 24-Mar-09

Scale: N/A

Version: 1

Page 24 of 24

Red Roof Inn Lumber Requirements and Cost Estimate

The following list is provided as an estimate of the required lumber to build one Red Roof Inn:

	6'	8'	10'	12'	14'	16'
6x6				2		
4x4			4			
2x12		1		1		2
2x10						
2x8						
2x6				2		
2x4		1	5	1	2	2
2x2			2		1	
1x12					1	2
1x10			1		8	
1x8						
1x6		1		6		
1x4						
1x2	1					

*The 1x2 could be replaced by just using a piece of 2x4 but in half.

**In addition to this list, one will need to purchase an 8'x4' section of 3/4" plywood.

This list was produced using hand calculations to optimize the cuts of wood required to create the pieces of the structure (i.e. find out the least amount of lumber needed to create all of the pieces).

The price listed below reflects current market values for RBS True Value Building Materials, INC in Northern New Mexico and is given only as an estimate. Prices will vary both by location and random market fluctuations. Using pricing provided by RBS the cost of a Red Roof Inn was estimated to be **\$446.29**

Date: October 20, 2008